

SPECIFICATIONS

Ellipsoidal lighting fixture

PHYSICAL Die cast aluminum construction
 Rotating shutter assembly $\pm 25^\circ$
 20 gauge stainless steel shutters in a tri-plane assembly
 Interchangeable lens tubes with smooth-running
 teflon guides provide six user-fit field angle options
 Thermally insulated rear handle
 High impact, thermally insulated knobs and
 shutter handles
 Two accessory slots, and a top mounted, gel
 frame retainer
 Steel yoke with two mounting positions
 Positive locking single-clutch fixture body
 Slot for glass or stainless steel patterns
 Slot with sliding cover for motorized pattern devices
 or optional iris
 UL and cUL listed

ELECTRICAL 115-240V, 50/60Hz
 High temperature 3-conductor 36" leads in a glass
 fiber outer sleeve
 Supports ETC Dimmer Doubling™ technology

LAMP 750W maximum
 HPL — compact tungsten filament contained in a
 krypton-filled quartz envelope (see table for suitable
 lamp types)
 Patented filament geometry makes for extremely
 efficient light collection and transmission
 Integral die cast aluminum heat sink lamp base

OPTICAL Projector-quality, high contrast aspheric lens
 Faceted borosilicate reflector with multi-layer
 dichroic coating
 95% of visible light reflected through the optical train
 90% of infrared radiation (heat) passes through
 the reflector
 Reflector secured with anti-vibration shock mounts
 Lens(es) secured with anti-vibration shock mounts
 Tool free lamp centering (X/Y) and peak/flat (Z)
 adjustment knobs
 Positive locking X, Y and Z adjustments, unaffected
 by relamping
 Beam edge continually adjustable hard-to-soft
 Interchangeable lens barrels permit selection of 5°, 10°,
 19°, 26°, 36°, and 50° field angles

ORDERING INFORMATION

Source Four

Model#	Description
450	50° ellipsoidal (black)
450-1	50° ellipsoidal (white)

ETC Source Four are supplied with C-clamp, color frame
 and 3' (96cm) leads as standard

Connector Designation

Use Suffixes below to specify Factory-Fitted Connector type

Model#	Description
A	Parallel-blade U-ground connector
B	Two-pin and ground, 20 amp connector
C	Grounded, 20 amp, twistlock connector
M	Dimmer Doubling™ Connector (NEMA L515P)

Source Four Accessories

Model#	Description
450LT	50° lens tube with lens installed (black)
450LT-1	50° lens tube with lens installed (white)
400CC	C-clamp (included)
400PH-A	Pattern holder (A size)
400PH-B	Pattern holder (B size)
400PH-G	Glass pattern holder
400SC	Safety cable
400RS	Drop-in iris
400CF	Colorframe (6.25") (included)
400DN	Donut (6.25")
400TH	Top hat
400HH	Half hat
400GE	Gel extender
407GE	Conical gel extender
407CF	7.5" Square color frame
400FB	Source Four Fixture Body, Single Clutch

Note: For colors other than black or white, please call ETC.



Source Four® 50°

450 Series

PHOTOMETRIC

All photometric data in this document was prepared using standard production fixtures, and the Prometric™ CCD measurement system. Fixtures were adjusted for cosine distribution, and were tested with a calibrated HPL 750/115V 21,900 lumens lamp at its rated voltage. All data were normalized to nominal lamp lumens.

50°

Distance (ft)	10	15	20	25
Field Diameter (ft)	9.5	14.3	19.0	23.8
Illumination (fc) (flat field)	349	155	87	56

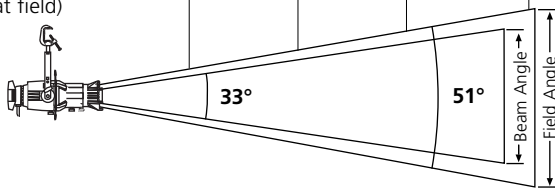

For illumination with any lamp, multiply the candlepower of a beam spread by the multiplying factor (mf) shown for that lamp.

To determine illumination in footcandles or lux at any throw distance, divide candlepower by distance squared.

For Field diameter at any distance, multiply distance by .95

For Beam diameter at any distance, multiply distance by .60

Metric Conversions: For Meters multiply feet by .3048
For Lux multiply footcandles by 10.76

Candlepower Distribution Curve (cosine)

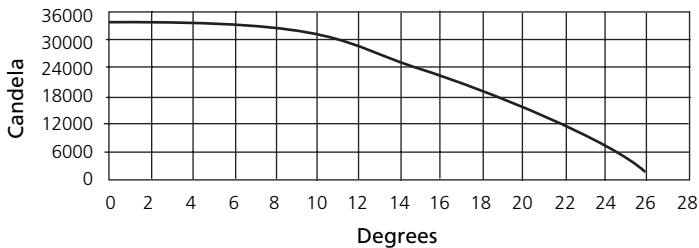

Source Four 50° cosine

Degree	Candlepower	Field Lumens	Beam Lumens	Efficiency
50°	34,900	12,400	8,220	56.6%

PHYSICAL

Lamp code	Watts	Volts	Initial Lumens	Color Temp.	Average Rated Life	MF
HPL 750/115	750	115	21,900	3,250°	300	1.00
HPL 575/115	575	115	16,520	3,250°	300	0.87
HPL 575/115X	575	115	12,360	3,050°	2000	0.66
HPL 575/120	575	120	16,460	3,250°	300	0.87
HPL 375/115	375	115	10,540	3,200°	300	0.55
HPL 375/115X	375	115	8,060	3,000°	1000	0.43
HPL 550/77*	550	77	16,170	3,250°	300	0.87
HPL 550/77X*	550	77	12,160	3,050°	2000	0.66
HPL 750/230	750	230	19,400	3,200°	300	0.90
HPL 750/240	750	240	19,400	3,200°	300	0.90
HPL 575/230	575	230	14,900	3,200°	400	0.76
HPL 575/240	575	240	14,900	3,200°	400	0.76
HPL 575/230X	575	230	11,780	3,050°	1500	0.61
HPL 575/240X	575	240	11,780	3,050°	1500	0.64
HPL 375/230X	375	230	7,800	3,050°	1000	0.38
HPL 375/240X	375	240	7,800	3,050°	1000	0.38

*77V lamps are intended for use with the ETC Dimmer Doubler™.

Warning: Use of lamps other than HPL will void UL/cUL safety approval and product warranty. Source Four is rated for 750W maximum.

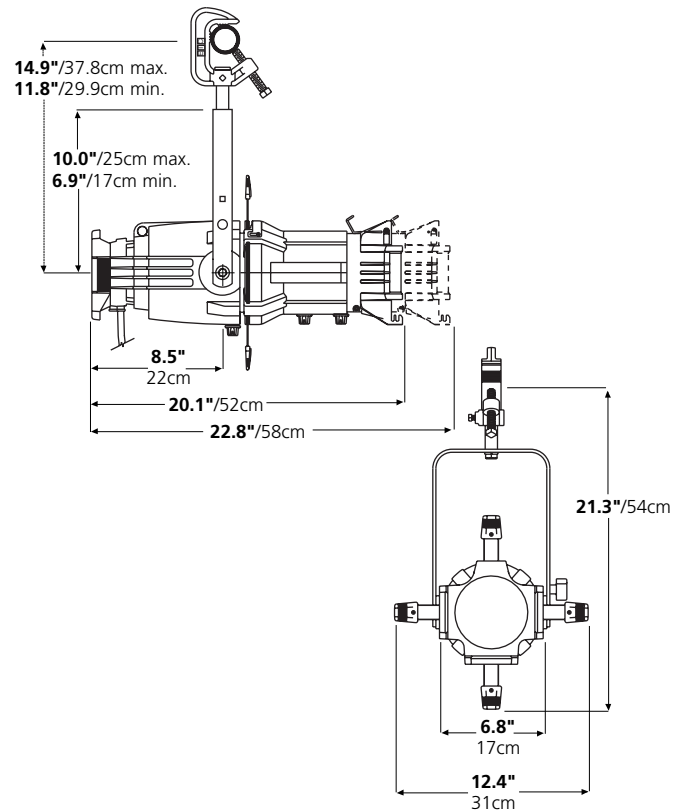

Source Four Weights

Model	Fixture Weight*		Shipping Weight	
	lbs	kgs	lbs	kgs
50°	14	6.3	20	9.1

* Add 2.3 lbs for C-clamp



Corporate Headquarters ■ 3031 Pleasant View Rd, PO Box 620979, Middleton WI 53562 0979 USA ■ Tel +1 608 831 4116 ■ Fax +1 608 836 1736
London, UK ■ Unit 26-28, Victoria Industrial Estate, Victoria Road, London W3 6UU, UK ■ Tel +44 (0)20 8896 1000 ■ Fax +44 (0)20 8896 2000
Rome, IT ■ Via Ennio Quirino Visconti, 11, 00193 Rome, Italy ■ Tel +39 (06) 32 111 683 ■ Fax +39 (06) 32 656 990
Holzkirchen, DE ■ Ohmstrasse 3, 83607 Holzkirchen, Germany ■ Tel +49 (80 24) 47 00-0 ■ Fax +49 (80 24) 47 00-3 00
Hong Kong ■ Room 605-606, Tower III Enterprise Square, 9 Sheung Yuet Road, Kowloon Bay, Kowloon, Hong Kong ■ Tel +852 2799 1220 ■ Fax +852 2799 9325
Web ■ www.etcconnect.com ■ Copyright © 2006 ETC. All Rights Reserved. All product information and specifications subject to change. 7060L1010 Rev. E Printed in USA 07/06

Source Four® products protected by U.S. Patent Numbers 5,268,613, 5,345,371, 5,544,029, 5,446,637 and 5,775,799; Japanese Patent Number 2,501,772; US and International Patents Pending.