

SELECON

PRODUCT SPECIFICATION



PACIFIC

90° FIXED BEAM

A base axial profile delivering a "cool" beam of light in a fixed beam of 90°. An energy efficient luminaire with active heat management system delivers longer life for filters, shutters and lower energy consumption.

FEATURES

- A unique new super wide 90° fixed beam profile with a high light output due to its unique reflector design.
- Cool light 'white' light. Over 80% of the heat is removed from the light beam by cold mirror and dissipated through the heat-sink.
- Base down lamp mounted axially in the reflector to maximise light collection.
- Choice of 600W, 800W, 1000W or 150W MH or MSR 575W lamp modules (each supplied with 1m mains cable).
- Accurate, simple & cool to use, lamp peak / flat adjustment.
- Two pattern / iris mounting positions / Rotatable lens tube.
- Constructed from aluminium pressure die-castings and injection moulded Fortron plastic components.
- Automatic disconnection of power on removal of lamp module. CE marked.
- Height adjustable yoke.

PHYSICAL DATA

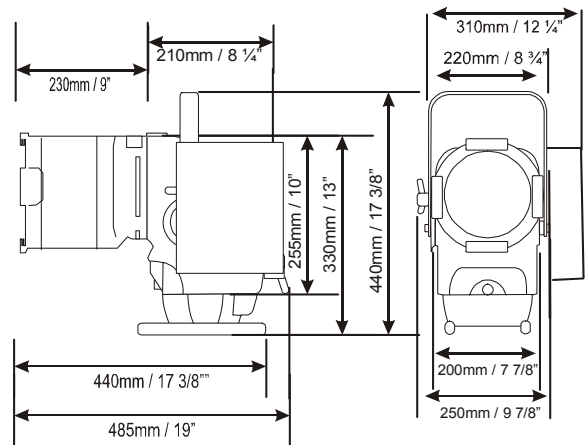

- Weight:** 9.1Kg
Carton Size: 650 x 425 x 300
Colour Frame Size: 185mm square
Gobo Size: A size, 75mm diameter image
Included: 1 x colour frame, 1 x heat sink guard, 1 x M12 suspension bolt set, instruction leaflet.

PHOTOMETRIC DATA

Tests conducted using standard 240V production lamps manufactured by Philips.

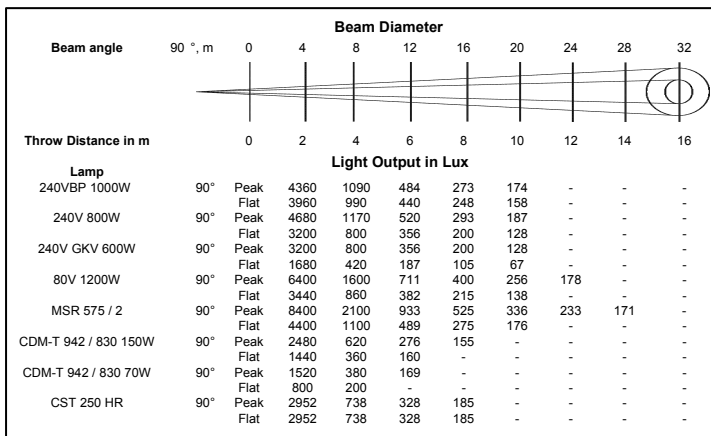

NB: The above CST 250 HR performance information relates to the NEW version of this lamp due for general release early 2006.

CST 250 HR 21,200 lumens 4,000hrs average life

LAMPS: 240V

GKV600W	15,000 lumens	300 hours average life
GLB600W	13,000 lumens	1500 hours average life
800W	22,000 lumens	400 hours average life
GAD1000WBP	25,000 lumens	250 hours average life
GAB1000W BP 230V	25,000 lumens	250 hours average life

ORDER CODES & ACCESSORIES

Pacific 90° Fixed Beam, 600W, 800W	18PAC90/6
Pacific 90° Fixed Beam, 1000W	18PAC90/1
Pacific 90° Fixed Beam CDM-150W	18PAC90/CDM
Pacific 90° Super Wide Lens tube only	18PACL90
Pacific Gobo Holder, 'A' Size	19PACGHA
Pacific Iris	20IRIS
Lens Safety Mesh	19PACSM1228
Suspension Hookclamp	20HC
Safety Bond	20SC

Selecon reserves the right to change the specifications without notice (11/06).

SELECON, THE ONLY FIXTURE MANUFACTURER TO OFFER A LIMITED THREE YEAR WARRANTY ON ENTERTAINMENT PRODUCTS
 © 2005 Selecon New Zealand Limited. All Rights Reserved.