

# ACCLAIM

## FRESNEL



**June 2007 – Selecon release a new model Acclaim Fresnel** which retains the many features of its industry-standard predecessor as well as introducing new design solutions, delivering an improved standard of operator ease and safety.

This 500W / 650W general purpose Fresnel (110mm diameter lens) for theatre, small studio and display lighting applications produces an adjustable cone of light with a soft edge, easily blended with adjacent beams to provide even illumination.

The Acclaim Fresnel is built Selecon tough from aluminium extrusion and moulded engineering plastics – robust, dependable, safe and easy to rig backed by the unique Selecon 3-year warranty for entertainment luminaires. Focusing is fast and safe using the large rear grab handle and heat protected focus knob and filter holder.

### FEATURES

- Up to 40% more light output than comparative Fresnel luminaires.
- A wide range of beam angles from 6°-60°.
- Integrated safety bond, rated for the fitting.
- Improved filter life through increased airflow.
- Cooler focus operation due to the use of engineering plastics on front (colour frame mount) and rear.
- Adjustable yoke balance point.
- ‘Swing-down’ side door for easy access to lamp or for cleaning. Micro-switch automatically isolates the mains power supply when opened. Lamps are quickly and safely removed using ejector mechanism.
- Lamp life is enhanced through judder-free focus action of the captive lamp/reflector assembly which moves on Teflon-coated bearings.
- Heat-insulated rear grab-handle which doubles as handy storage for the 1m cable length.
- New barndoor design, cool to focus maintaining settings through unique hinge tension design - retro-fittable.
- CE marked for use by all, not just professionals.

### PHYSICAL DATA

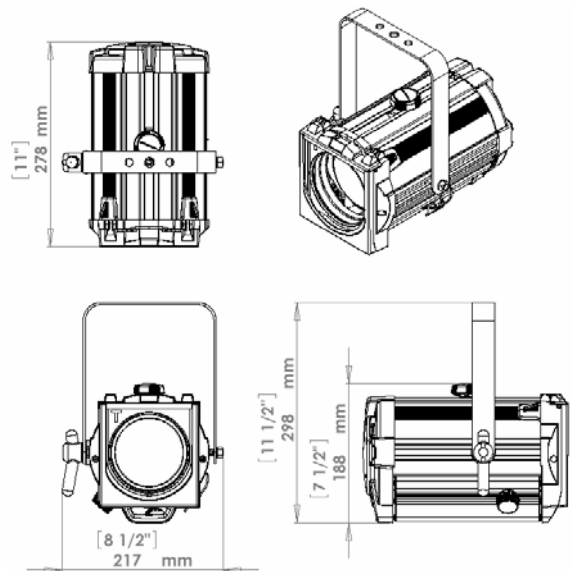

**Weight:** 3.3kg **Packed:** 3.7kg  
**Carton Size:** 420 x 225 x 175 **Cubic:** 0.016  
**Colour Frame Size:** 125mm x 125mm  
**Luminaire with integrated safety bond supplied with:** 1 x colour frame, 1 x M12 nut & bolt set and instruction leaflet.

### PHOTOMETRIC DATA

Tests conducted using a standard T27, 650W, 240V, 15,000 lumens lamp.

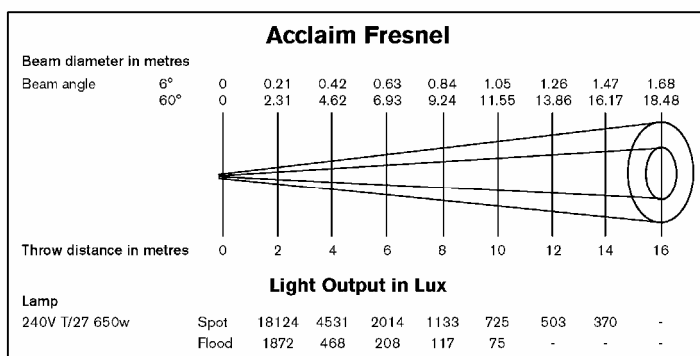

### LAMPS: 220V-240V

**500W T/25, T/18** 11,000 lumens 400hrs average life  
**500W M40** 10,000 lumens 2000hrs average life  
**650W T/26, T/27** 14,500 lumens 600hrs average life

### ORDER CODES & ACCESSORIES

**Acclaim Fresnel** 12ACFMS  
**Barndoor** 20BDMF  
**Lens Safety Mesh** 15ACSM  
**Suspension Hookclamp** 20HC

Selecon reserves the right to change the specifications without notice (June 2007).