



ACCLAIM

ZOOMSPOT

A 500W / 650W variable beam profile providing precise beam control and pattern projection capability. The ellipsoidal optical system provides a high output beam with a centre peak. This can be made more even (2:1) by adjusting the position of the lamp in the reflector.

The Acclaim Zoomspot offers efficiency, strength and performance with a choice of two beam angle ranges.

FEATURES

- Over 50% more light than most other base down 'T' class 650W luminaires.
- Available in 18°-34° or 24°-44° beam angles.
- Interchangeable lens tray between Medium and Wide versions.
- Uniquely shaped shutters offer wider degree of masking angles.
- Adjustable beam Peak-Flat setting.
- Slot provided for Iris or rotatable (35°) pattern holder.
- Cranked yoke with adjustable balance point.
- 'Swing-down' doors for easy access to lamp or lens cleaning. Isolates the mains supply when opened.
- Captive lamp/ reflector focus system.
- Constructed of pressure die-castings and aluminium extrusion.
- Fully tested and compliant to CE standards.

PHYSICAL DATA

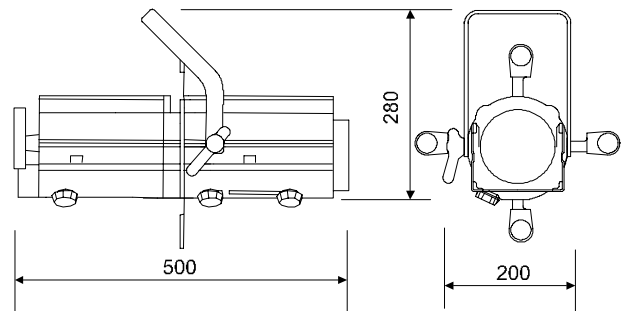

- Weight:** 5.1kg
- Packed Weight:** 5.7kg
- Carton Size:** 610 x 225 x 180
- Carton Size Cubic:** 0.025
- Colour Frame Size:** 125mm x 125mm
- Pattern (Gobo) Size:** M
- Included:** 4 x shutters, 1 x colour frame, 1 x M12 nut & bolt set, instruction sheet.

PHOTOMETRIC DATA

Tests conducted using a standard T27, 650W, 240V, 15,000 lumens lamp.

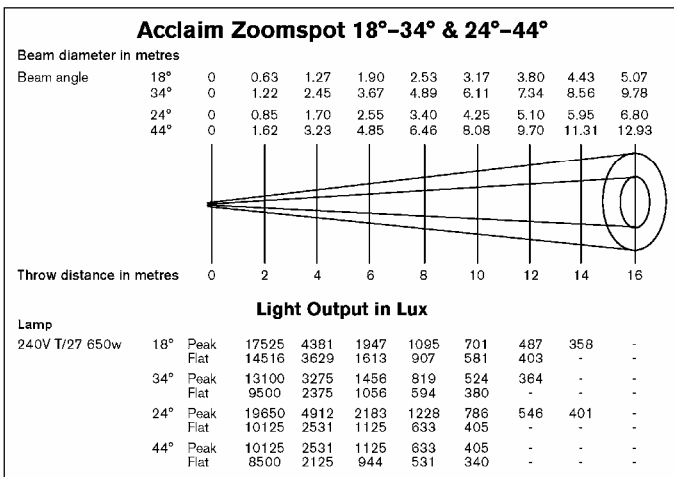

LAMPS: 220V-240V

	500W	
T/25, T/18	11,000 lumens	400 hours average life
	650W	
T/26, T/27	14,500 lumens	600 hours average life

ORDER CODES & ACCESSORIES

Acclaim Zoomspot 18°-34°	12ACZSMS
Acclaim Zoomspot 24°-44°	12ACZSWMS
Acclaim Iris	15ACIRIS
Acclaim Rotatable Pattern Holder	15ACGH
Acclaim 18°-32° Lens Tray	15ACLT5
Acclaim 24°-44° Lens Tray	15ACLTW
Lens Safety Mesh	15ACSM
Suspension Hookclamp	20HC
Safety Bond	20SC

Selecon reserves the right to change the specifications without notice (09/06).